

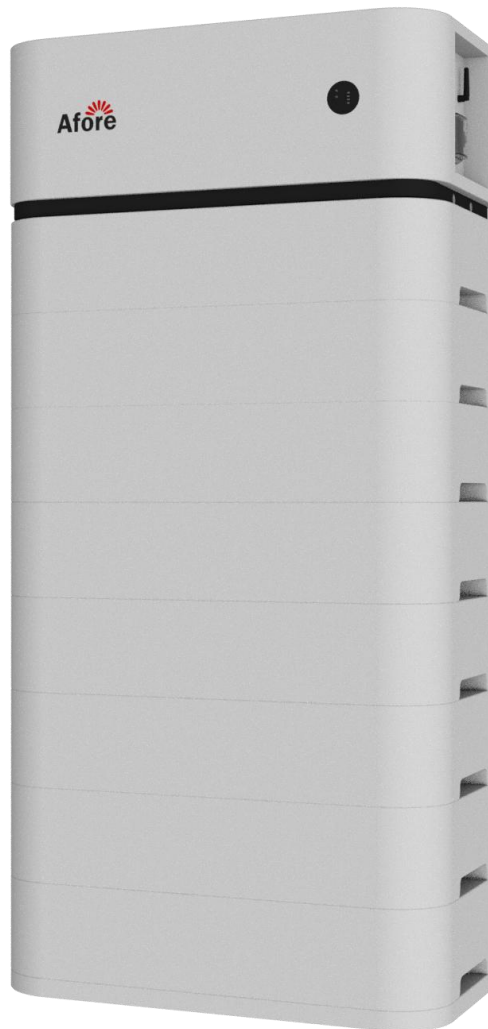

AF-HT series Operation Manual

Version No.:V1.0



Afore New Energy Technology(Shanghai) Co., Ltd

Disclaimer

Copyright © Afore New Energy Technology (Shanghai) Co., Ltd. 2023. All rights reserved.

No part of this document may be reproduced or transmitted in any form or by any means without prior written consent of Afore New Energy Technology (Shanghai) Co., Ltd.

The material furnished in this document is believed to be accurate and reliable. The information and recommendations in this document do not constitute commitments or warranties in the form of assignments. The information in this document is subject to change without notice. You may refer to the official website (<https://cn.aforeenergy.com>) for the most updated version.

This document is intended only for the AF-HT battery system, excluding the hybrid inverter or any other equipment. Please keep the Manual properly and operate in strict accordance with all safety and operating instructions in this Manual. Please do not operate the product before reading through the Manual.

All brands and product names are trademarks or registered trademarks of their respective holders.

This Manual introduces AF-HT manufactured by Afore. Please read this manual before you install the product and follow the instructions carefully during the installation process. Should you have any confusion, please contact Afore for advice and clarification.

CONTENTS

1.Introduction	1
1.1 Content and Structure of this Document.....	1
1.2 Target Group.....	1
1.3 Levels of Warning Messages.....	1
1.4 Definition of Abbreviations and Nouns.....	2
2.Safety	3
2.1 Safety Instruction	3
2.2 Battery precautions	3
2.3 Emergency situation	4
3.System Introduction	5
3.1 Specifications.....	5
3.1.1 Parameters of system	5
3.1.2 Pack	6
3.1.3 Battery Control Box	8
3.2 Application scenario	11
3.3 Features.....	11
4.Installation	11
4.1 Tools and safety gear	11
4.2 Package items	13
4.3 Installation Environment	13
4.4 Installation Location	14
4.5 Module Installation	17
4.6 Cables Connection.....	22
4.7 Operation requirements.....	26
4.8 Power on	27
4.9 Power off	27
5.Transport and Maintenance	28
5.1 Capacity calibration	28
5.2 Annual inspection.....	28
5.3Transport requirement	28
5.4 Storage	29
5.4 Equipment Maintenance and Replacement.....	29
5.5 Disposal instructions.....	30

1.Introduction

1.1 Content and Structure of this Document

This document is valid for AF-HT battery system.

This document describes the product information, and guidance for installation, as well as commissioning.

Observe all documentation that accompanies the product, keep them in a convenient place and available at all times.

Illustrations in this document are reduced to the essential information and may deviate from the real product.

1.2 Target Group

Only qualified persons are allowed to perform the operations marked with a warning symbol in this document. Qualified persons must have:

- Knowledge of working principle of Li-ion battery.
- Knowledge of how to deal with the dangers and risks associated with installing and using electrical devices, batteries and systems.
- Knowledge of the installation and commissioning of electrical devices and systems.
- Knowledge of the applicable standards and directives.
- Understood and complied with this document, including all safety precautions.
- Understood and complied with the documents of the inverter manufacturer, all safety precautions included.

1.3 Levels of Warning Messages



DANGER

DANGER indicates a hazardous situation which, if not avoided, will result in death or serious injury.



WARNING

WARNING indicates a hazardous situation which, if not avoided, could result in death or serious injury.



CAUTION

CAUTION indicates a hazardous situation which, if not avoided, could result in minor or moderate injury.



NOTICE

NOTICE indicates a situation which, if not avoided, can result in property damage.



Warning electric shock.



Warning Fire.



Do not reverse connect the positive and negative.



Do not place near open flame.



Do not place at the children or pet touchable area.

1.4 Definition of Abbreviations and Nouns

Abbreviation	Noun
AC	alternating current
BAT	battery
BMS	battery management system
DC	direct current
INV	inverter
PV	photovoltaic
SOC	state of charge
SOH	state of health

2.Safety

2.1 Safety Instruction

This product is designed and tested in accordance with international safety requirements IEC 62619, IEC 63056, and IEC 62040, but as with all electrical and electronic equipment, certain precautions must be observed when installing and operating the product. To reduce the risk of personal injury and ensure the safe installation and operation of the product, more attention should be paid on following all instructions, cautions and warnings in this Manual.

2.2 Battery precautions



WARNING

It is important and necessary to read the user manual carefully before installing or using battery. Failure to do so or to follow any of the instructions or warnings in this document can result in electrical shock, serious injury, or death, or can damage battery, potentially rendering it inoperable.

- If the battery is stored for long time, it is required to charge it every six months, and the recommended SOC should be 50%~55%. The battery shall not be stored for more than 12 months if the storage temperature is -10 ~ 25°C, not more than 6 months if the storage temperature is 25 ~ 35°C and not more than 3 months if the storage temperature is 35 ~ 50°C.
- Battery needs to be recharged within 12 hours after being fully discharged.
- Do not have the product installed in any environment that falls outside the range of temperature or humidity set out in the Manual.
- Do not expose cable outside.
- Do not connect power terminal reversely.
- All the power terminals must be disconnected for maintenance.
- Please contact the supplier within 24 hours in case of anything abnormal.
- Do not use cleaning solvents to clean battery.
- Do not expose battery to flammable or harsh chemicals or vapors.
- Do not paint any part of battery, include any internal or external components.
- Do not connect battery with PV solar wiring directly.
- Any foreign object is prohibited to insert into any part of battery.
- The warranty claims are excluded for direct or indirect damage due to above

reasons.

2.3 Emergency situation



DANGER

This product is designed with multiple safety strategies to prevent hazards resulting from failure. However, hazards and dangers could emerge in few uncertain situations.

2.3.1 Fire

The battery pack may catch fire when heated over 150°C.

Ensure an ABC or carbon dioxide extinguisher nearby the battery, and do not use water to extinguish the fire.

If a fire breaks out where the battery is installed, perform the following actions:

- Extinguish the fire before the battery catches fire.
- If the battery has caught fire, do not try to extinguish the fire. The fired battery will produce poisonous gases, please evacuate people immediately.

2.3.2 Leaking

If the battery pack leaks, avoid contact with the leaking liquid or gas.

Electrolyte is corrosive and contact may cause skin irritation and chemical burns. If one is exposed to the leaked substance, perform the following actions:

Inhalation: Evacuate the contaminated area and seek medical attention immediately.

Eyes contact: Rinse eyes with flowing water for 15 minutes and seek medical attention immediately.

Skin contact: Wash the affected area thoroughly with soap and water and seek medical attention immediately.

Ingestion: Induce vomiting as soon as possible and seek medical attention immediately.

2.3.3 Wet battery

If the battery is wet or submerged in water, do not try to access it. Contact customer service for technical assistance.

2.3.4 Damaged battery

Damaged battery may emit toxic gas or/and flammable gas, which could cause hazards to lives or property. If the battery is damaged, please keep away from the battery and contact customer service for help as soon as possible.

3.System Introduction

3.1 Specifications

3.1.1 Parameters of system

Battery Cell Technology	Li-iron (LFP)						
Battery Type/model	AF10000W-HT	AF15000W-HT	AF20000W-HT	AF25000W-HT	AF30000W-HT	AF35000W-HT	AF40000W-HT
Number of Pack (pcs)	2	3	4	5	6	7	8
Total energy (kWh)	10.44	15.66	20.88	26.11	31.33	36.55	41.77
Usable Energy*(kWh)	10.44	15.66	20.88	26.11	31.33	36.55	41.77
Voltage Range(Vd.c.)	89.6~115.2	134.4~172.8	179.2~230.4	224.0~288.0	268.8~345.6	313.6~403.2	358.4~460.8
Nominal Voltage(Vd.c.)	102.4	153.6	204.8	256	307.2	358.4	409.6
Max. Charge Voltage(Vd.c.)	115.2	172.8	230.4	288	345.6	403.2	460.8
Max. continuous charging current(A)	50						
Max. continuous discharge current(A)	50						
DOD(%)	95						
Communication	CAN/RS485						
Dimension(L*W*H),mm	(720±2) * (420±2) * (616±3)	(720±2) * (420±2) * (766±5)	(720±2) * (420±2) * (916±7)	(720±2) * (420±2) * (1066±9)	(720±2) * (420±2) * (1216±11)	(720±2) * (420±2) * (1366±13)	(720±2) * (420±2) * (1516±13)
Net Weight(kg)	(116±3)	(163±5)	(210±7)	(257±9)	(304±11)	(351±13)	(398±13)
Operating Condition	Indoor or outdoor						
Operating Temperature	Charging: 0~50°C						
	Discharging: -15~50°C						

Humidity	15%~85%RH (No Condensation)
Cooling type	Natural
WIFI Frequency Range	2412MHz~2472MHz
WIFI Maximum Transmission Power	20dBm
IP rating of enclosure	IP66
Installation method	Stacked installation
Supply connection	Fixed power cord
Authentication Level	IEC62619:2022, including IEC60730-1,EN IEC 61000-6-1:2019,EN IEC 61000-6-3:2021,EN IEC 61000-3-2:2019/A1:2021, EN 61000-3-3:2013/A2:2021,EN 301 489-1 V2.2.3,Draft EN 301 489-17 V3.2.5,EN 300 328 V2.2.2,EN 50663:2017,IEC62040 EN 62311:2008,IEC60529,IEC60068-2-52:2017,UN38.3/MSDS

** Testing conditions based on temperature 25 °C at the beginning of life. Total Energy/Usable Energy are measured with a standard test method: 0.2C Charge and Discharge. After the battery is fully charged or fully placed, it is recommended to let it stand for 1.5 hours to ensure that the battery is fully cooled to provide better power output. As per the characteristics of lithium batteries, such parameters as the charge/ discharge current and efficiency listed above are subject to change. The final right of interpretation is reserved by Afore New Energy Technology(Shanghai) Co., Ltd.*

3.1.2 Pack



Battery Module Type	AF5000W-HM
Total energy	5.22 kWh
Usable Energy*	5.22 kWh
Voltage Range	44.8~57.6 Vd.c.
Nominal Voltages	51.2 Vd.c.
Max. Charge Voltage	57.6 Vd.c.
Max.continuous charging current	50 A
Max.continuous discharge current	50 A
DOD	95%
Dimension(L*W*H)	(720±2)*(420±2)*(174±3)mm
Net Weight	(47±2)kg
Operating Condition	Indoor or outdoor
Operating Temperature	-15~50°C
Humidity	15%~85%RH (No Condensation)
Heating film power (optional)	260W

3.1.3 Battery Control Box



1) Battery Control Box Display Panel

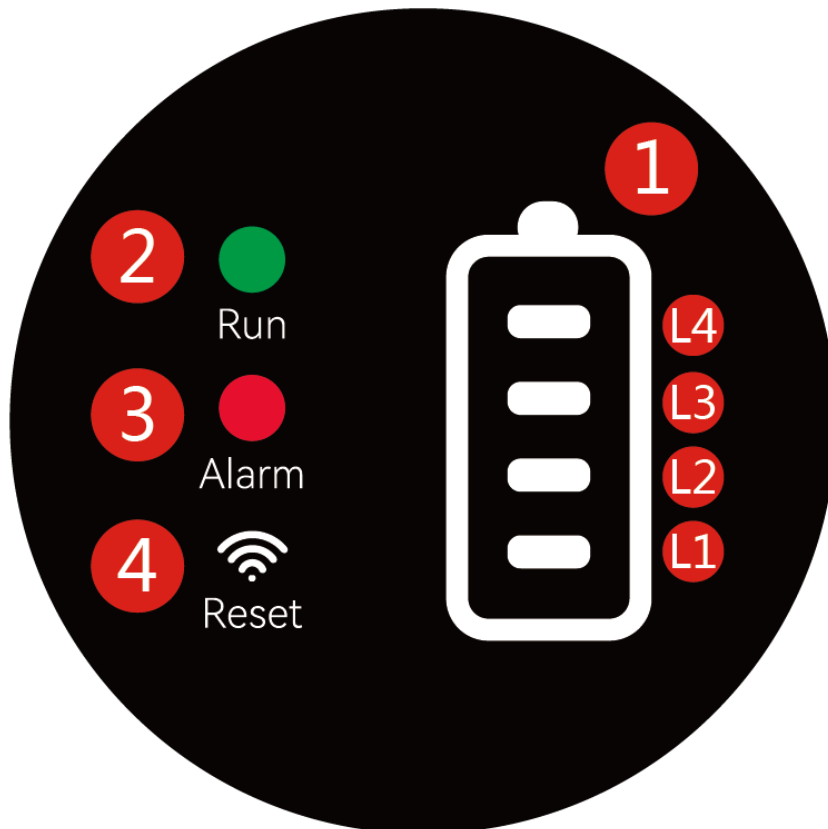

Object	Name		Description			
①	SOC indicator		L4	L3	L2	L1
			●	●	●	●
	SOC (%)	0%~25%	OFF	OFF	OFF	ON
		26%~50%	OFF	OFF	ON	ON
		51%~75%	OFF	ON	ON	ON
76%~100%		ON	ON	ON	ON	
②	RUN ●		1) Standby: blink slowly for every 500ms;			
			2) Charging: ON;			
			3) Discharge: blink quickly for every 100ms ;			
③	Fault ●		The indicator is on when third-level alarm is triggered. See assistance from local distributor;			
④	WIFI Reset		If WiFi is to be reconnected, press the button and hold for 5s till the WIFI icon on the screen flashes, and then proceed with WiFi;			

2) Battery Control Box Interface Panel

All ports are shown in the figure, and detailed information is shown in the table below

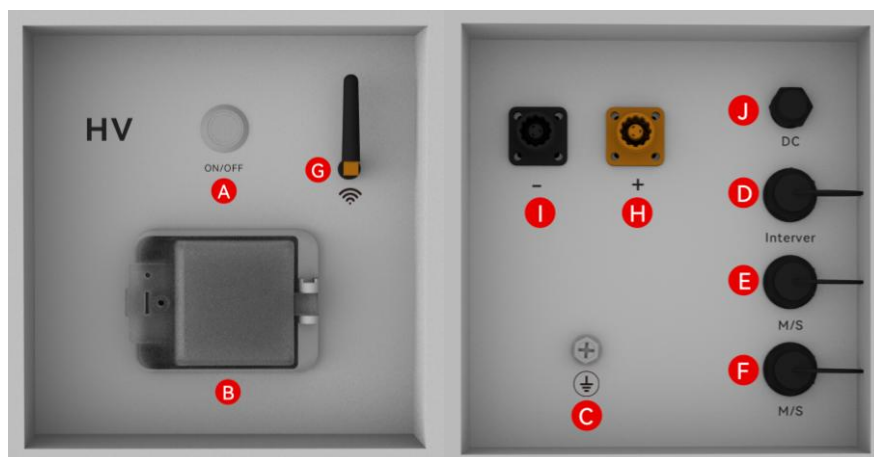

Object	Name	Description
A	ON/OFF	1. When battery and inverter have completed power & communication connections, and the inverter is operational: With circuit breaker ON, short-press the ON/OFF button for 1 second to activate the system

		<p>m; long-press for 3 seconds to initiate shutdown.</p> <p>2. When battery and inverter lack power/communication connections or inverter is inactive: with circuit breaker ON, long-press ON/OFF button for 10+ seconds to start the system; long-press for 3 seconds to deactivate the system.</p> <p>3. Press and hold the button for 30s to enter Force Charging mode.</p>
B	Breaker	<p>ON: main breaker ON, able to turn on battery system by ON/OFF button.</p> <p>OFF: battery system turn off completely, no power output,</p>
C	GND ⁴	Grounding protection
D	Inverter	Communication port to inverter
E/F	M/S	Communication ports to parallel batteries
G	WIFI Antenna	--
H	BAT+	Battery anode
I	BAT-	Battery cathode
J	DC	Power supply for the main controller, for commissioning by specialized personnel only

¹: In case of fault, e.g., overcharge, over-discharge, overcurrent, and over-temperature, the red light will keep on

²: When battery system is under normal running, the green light will keep on

³: This product can cause a d.c. current in the PE conductor. Where a residual current-operated protective device (RCD) is used for protection against electrical shock, only an RCD of Type B is allowed on the supply side of this product.

⁴: Battery system monitoring is achieved through inverter monitoring.

3.2 Application scenario

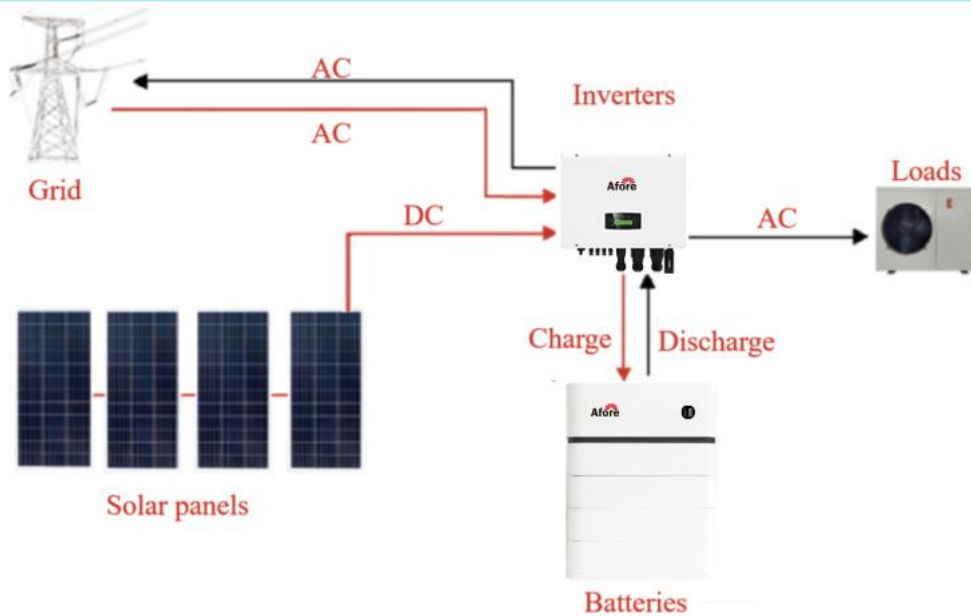

3.3 Features

- The battery is non-toxic, pollution-free and environmental-friendly.
- Anode material is made from LiFePO_4 with safety performance and long cycle life.
- Support upgrade BMS software via APP.
- BMS has protection functions including over-discharge, over-charge, over-current and high/low temperature.
- Flexible configuration, multiple battery modules can be connected in series to increase storage energy.
- The product also supports parallel connection up to 6 strings of 8 stacks of AF-HT battery via Power Port for a maximum capacity of 250.56kWh.

4. Installation

4.1 Tools and safety gear

The displayed tools are recommended and could be used in the installation of battery or batteries. And the safety gear should be worn correctly during installation.

During operation, consider that the noise emitted based on the environment could possibly exceed the legal thresholds (less than 70 dBA), therefore, suitable ear protection must be worn.

		
Screwdriver	Wire cutter	Crimping modular plier
		
Voltmeter	Pocket knife	Insulating tape
		
Insulated gloves	Safety goggles	Safety shoes
		
Socket wrench	Percussion drill	Measuring tape
		
Spirit level	Dust mask	Safety helmet

4.2 Package items

Battery Control Box		
Item	Description	Set
1	Battery Control Box	1
2	Pedestal	1
3	1.5m ground wire (6AWG)	1
4	M6*12 Pack connection screws	4
5	1.5m communication cable to inverter communication port	1
6	Operation Manual and Warranty Card	1
7	Product Qualification Pass	1
8	Test Report	1
9	Packing List	1
PACK		
1	PACK	1
2	M6*12 Pack connection screws	4
3	Packing List	1

4.3 Installation Environment

Ensure the installation environment meets the following requirements:

- There are no flammable or explosive materials nearby
- Do not install the device in environments with smoke, flammable, or explosive materials
- Avoid installing the device in direct sunlight, rain, standing water, snow accumulation, dust, or sand. It is recommended to install it in a sheltered location. If the area is prone to natural disasters such as floods, mudslides, earthquakes, or typhoons, necessary protective measures should be taken during installation.
- Do not install the device in environments with strong electromagnetic interference.

- The ambient temperature is within the range from 0°C to 40°C.
- The temperature and humidity (15%~85%RH(No Condensation)) are maintained at a constant level.
- There is minimal dust and dirt in the area.
- There are no mandatory ventilation requirements for battery module, but please avoid of installation in confined area. The aeration shall avoid of high salinity, humidity or temperature.
- The battery system should be used in PD2 environment.

When the battery system is installed outdoors, it must be properly protected. Do not expose the battery system directly to sunlight, water, rain, snow, spray, lightning, or similar environmental conditions.

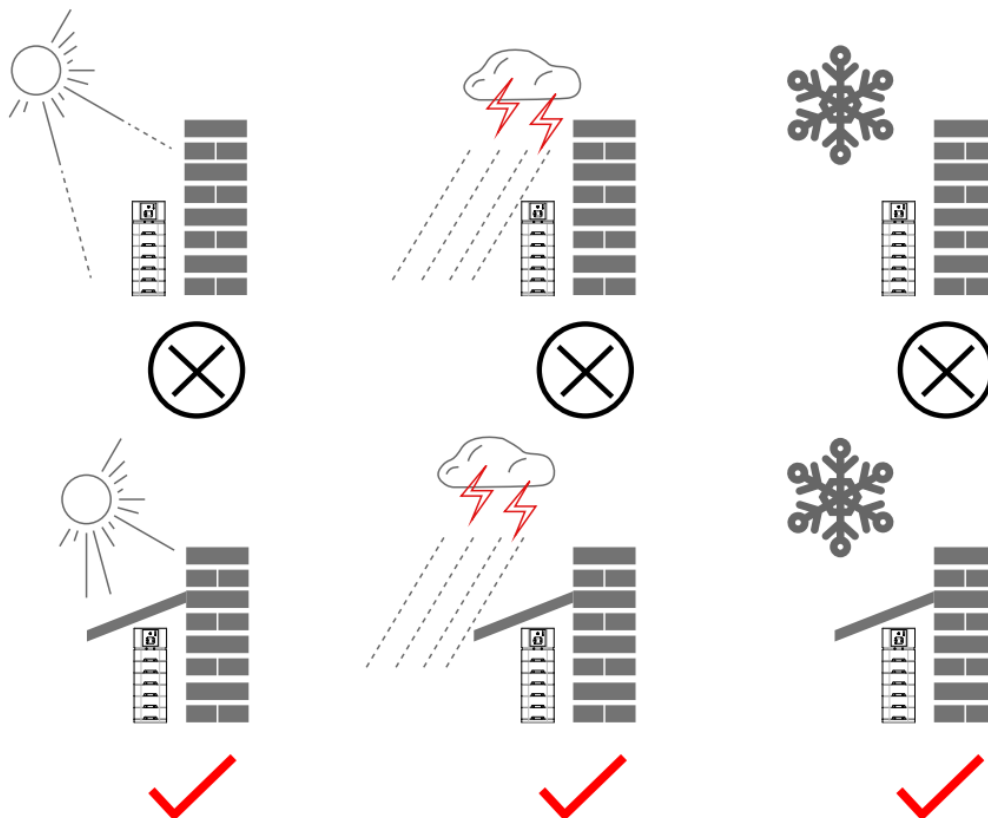

4.4 Installation Location

Ensure the installation location meets the following requirements:

- Do not tilt or invert the equipment. The floor must be flat and level to ensure the equipment is installed horizontally.
- Do not install the equipment in a location easily accessible to children.
- Do not install the equipment near sources of fire or in damp locations.
- Do not install the equipment in enclosed, unventilated spaces that lack

firefighting facilities and are difficult for firefighters to access.

- The distance from heat source is more than 2 meters.
- The distance from air outlet of inverter is more than 0.5 meters.
- According to the on-site situation, the equipment should be fixed to the wall during installation against the wall.
- Please install the battery on flat ground, if the ground is waterlogged, built a waterproof platform that meets the load-bearing requirement.
- The battery pack supports a maximum of 8-layer stacking, and the total height of the fully assembled stacked system is (1516±13) mm.
- Make sure the ground surface is flat prior to installation. Generally, fixating support is not need. Under specific circumstances, when the horizontal inclination between battery and horizontal plane is 3°, fixating support (as shown in the Fig. below) must be mounted.

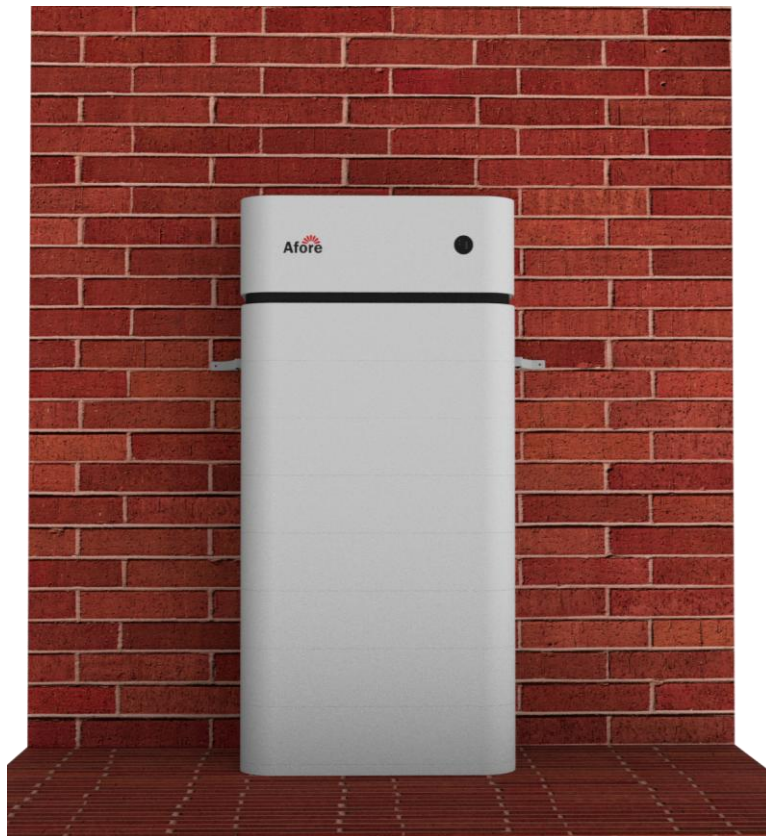

Allow adequate space around the battery system for installation and maintenance access. Do not install battery near flammable walls, if unavoidable, add a fireproof layer between the battery and wall.





CAUTION

- I. In actual installation, the selection of the installation location must comply with local fire safety, environmental protection, and other regulations. The specific installation location plan shall be determined by the installer or EPC (Engineering, Procurement, Construction) contractor.
- II. If the ambient temperature is out of the operating range, the battery stops operating to protect itself. The optimal temperature for the battery pack ranges from 10°C to 40°C. Frequent exposures to harsh temperatures may deteriorate the performance and life of the battery.

4.5 Module Installation

- 1) Place the pedestal in the right place (**the details about installation position described in chapter 4.3 & 4.4**)



- 2) Place battery pack in the right place of the pedestal. **CAUTION: align the**

battery pack and pedestal before putting it on, make sure the couplings are on the same line to avoid any structural damage.

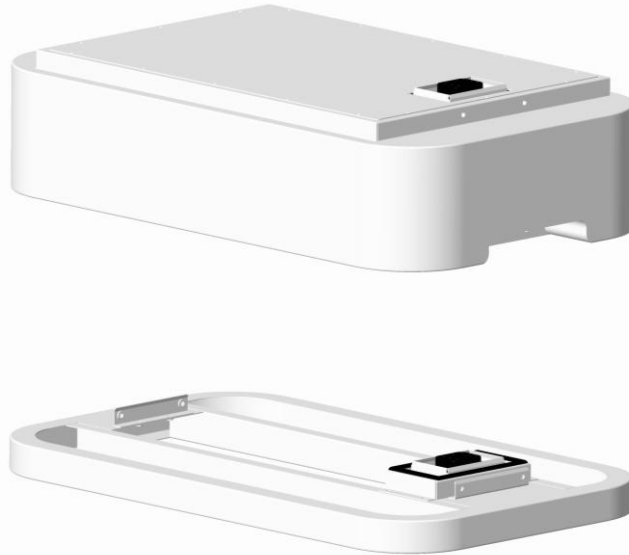

Before placing battery pack or Battery Control Box on the pedestal, please align it with the pedestal and make sure the couplings are on the same line to avoid any structural damage or render installation impossible. Since each pack is as heavy as 47kg, if mechanical tools are not available, it is recommended to have at least 2 workers working on battery installation.

- 3) The stacking connector is rated IPXXB. Contact with live parts is prohibited.
- 4) The modules are connected in series using a stacked configuration.
- 5) The modules are de-energised during stacking/unstacking.
- 6) Stack battery packs (8 at most) on the pedestal before placing the Battery Control Box on top of the last battery pack.

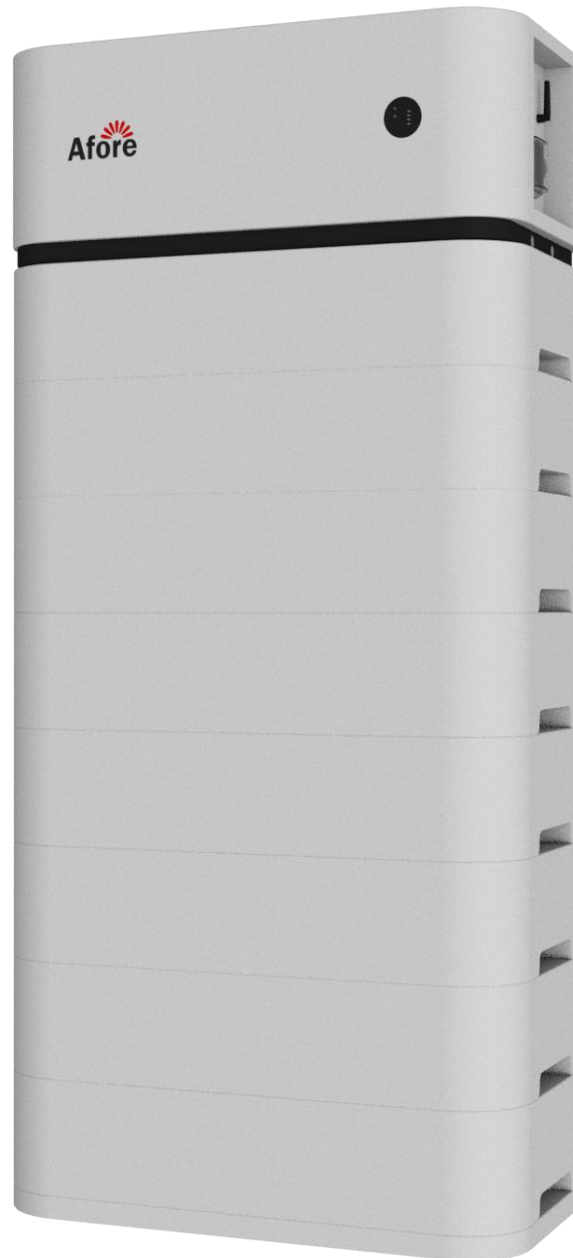

- 7) Tighten M6*12 screws into the threaded holes on both sides of Battery Control Box and each pack. Threaded holes on one side are coated with conductive paint to ensure the equipotential bonding of the whole battery case after being tightened with screws.

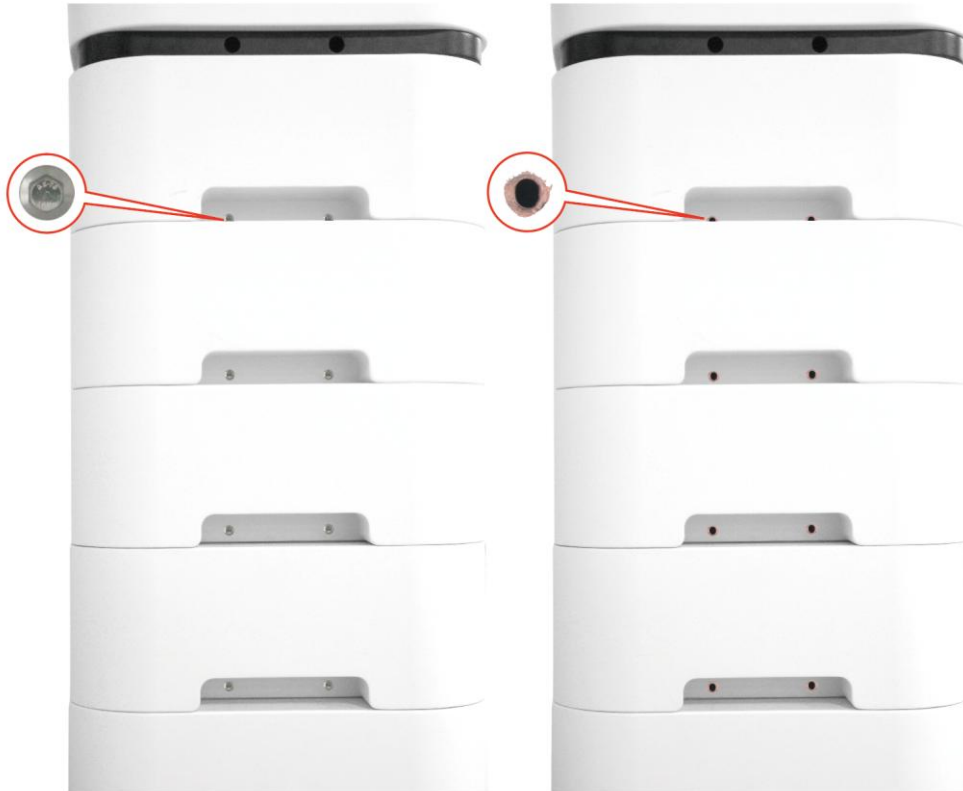

- 8) Connect the ground cable to the grounding point of the Battery Control Box. Ground cable is 6 AWG. The cable shall be copper with yellow-green color.



4.6 Cables Connection

4.6.1 Single battery system

- 1) Connect the communication cable by leading it from the inverter port of Battery Control Box to the inverter BMS port.

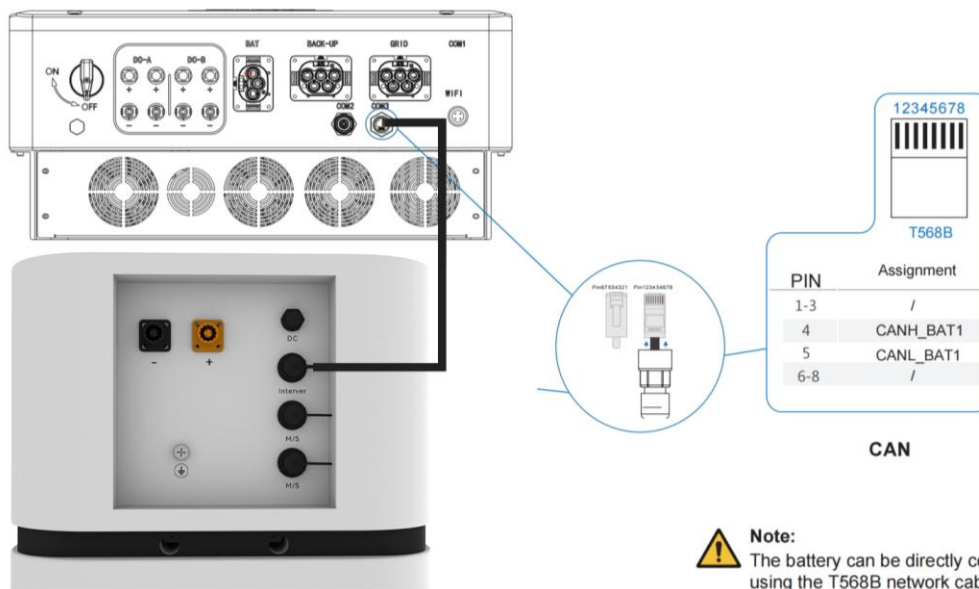
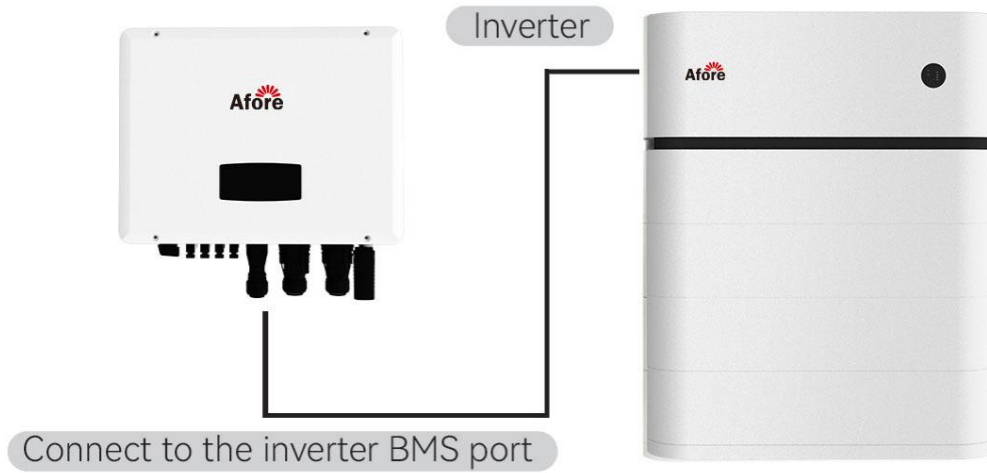

Note:
 The battery can be directly connected using the T568B network cable

- 2) Connect BAT+ and BAT- power cables by leading them from Battery Control Box to corresponding ports of inverter.

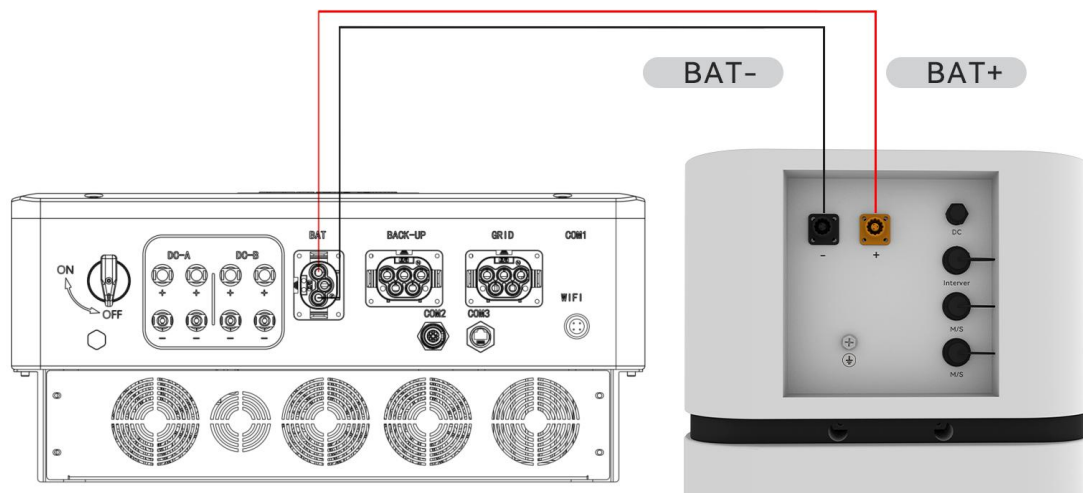
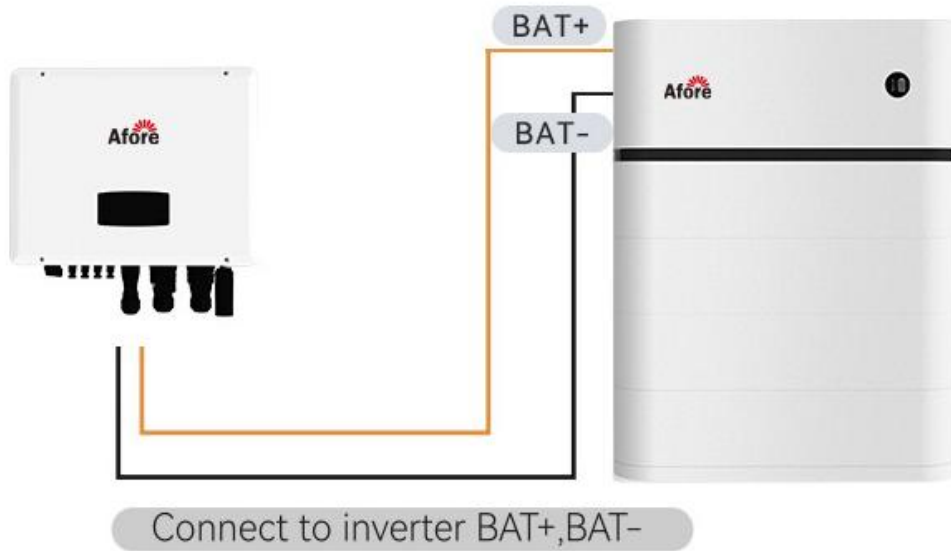

NOTICE

The AF-HT battery system is designed to support both CAN and RS485 communication with the inverter.



CAUTION

- I. For Australian market, an overcurrent and disconnection device that isolates all live conductors (positive and negative) is required between the battery system and the inverter.
- II. In Australia installations should be conducted in accordance with AS/NZS 3000 and AS/NZS 5139.

4.6.2 Multi stake connection

The product also supports parallel connection up to 6 strings of 8 stacks of AF-HT battery via Power Port for a maximum capacity of 250.56kWh, For parallel connection of battery systems, a battery combiner box (including terminal resistor) shall be separately purchased (available at additional cost). In addition, a DC cable to be connected between the output terminal of battery combiner box and the BAT terminal of inverter shall be additionally prepared by the user (some inverter suppliers may provide such cable in the packing items). The output terminal of the battery combiner box is compatible with 2 - 4 AWG cables (outer diameter 9 -12mm).

S.N.	Description	Quantity (pcs)	Remarks
1	Combiner box (including terminal resistor)	1	Provided at additional cost
2	2~4AWG cable	1	Provided together with the inverter or separately prepared by the user. The cable is used for connection Between the output terminal of battery combiner box and the BAT terminal of inverter.

The following Figs demonstrate wiring diagram of 3 strings of 4*5.22kWh battery systems.

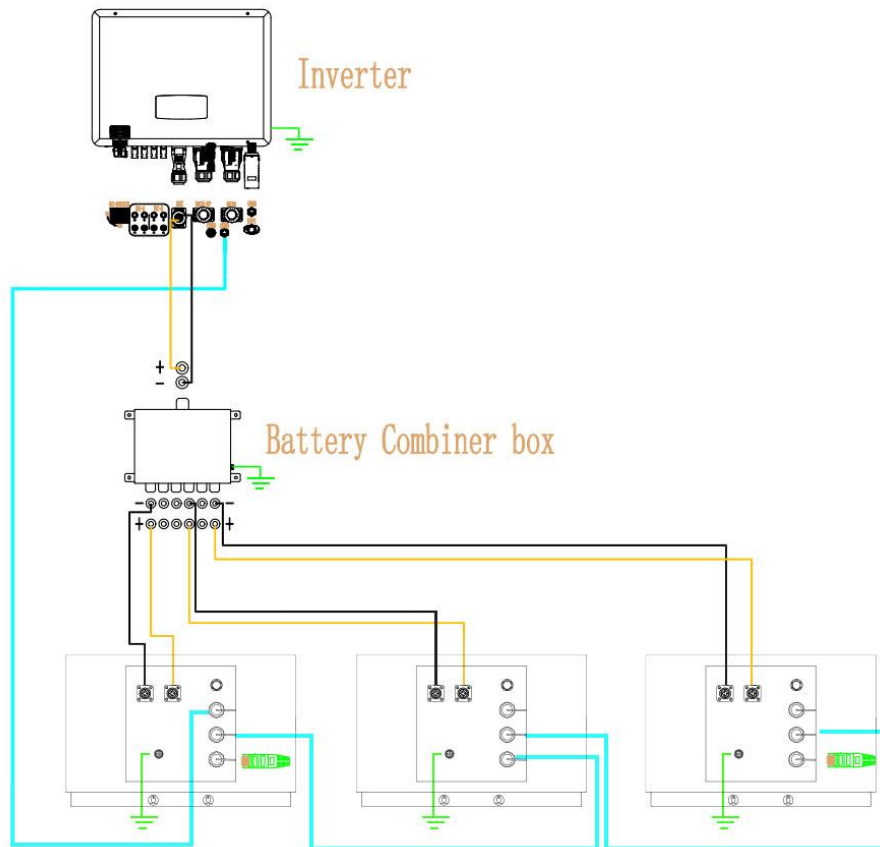

Schematic diagram featuring parallel connection of 3 battery systems

Positive cable		terminal resistor	
Negative cable		Communication cable	
Ground wire			

- ◆ Before parallel connection, make sure the SOC of each battery system is identical. Measure the voltage with multimeter at the +/- interface of the Control Box and make sure the voltage difference of each battery system is less than 1.5V.

- ◆ Only Master battery is allowed to communicate with the inverter via RS485 or CAN interface.
- ◆ Communication between Master and Slave, Slave and Slave is realized via M/S interface. Both the Master and the last Slave shall be equipped with terminal resistance.
- ◆ Before connected to the inverter, +/- power cables leading from the battery system shall go through the combiner box first.

4.7 Operation requirements



DANGER

Personnel responsible for the installation and maintenance of the equipment must undergo rigorous training and obtain relevant certifications. They must be familiar with local laws, regulations, and applicable standards, understand the battery system's composition and working principles, be aware of all safety precautions, master correct operating methods, and possess the operational qualifications required by the country where the work is performed.

- ◆ Do not perform live work (including but not limited to installation, wiring, replacement, etc.). Before any operation, ensure that all power supplies to the equipment are disconnected, including but not limited to the grid-side, inverter, and diesel generator power switches.
- ◆ Do not use sharp objects to contact the battery pack connectors.
- ◆ Do not operate the equipment in severe weather conditions (including but not limited to thunderstorms, rain, snow, typhoons, etc.).
- ◆ Do not clean or immerse the equipment with water, alcohol, oil, etc., to prevent electric leakage or electrolyte leakage from the battery pack.
- ◆ Do not strike, drag, or step on the equipment.
- ◆ Before operating the equipment, inspect it for damage. If any abnormality is found (such as physical deformation, unusual odors, etc.), do not operate the equipment.
- ◆ Before starting work, wear protective gear such as insulated gloves, insulated shoes, and a safety helmet.
- ◆ Use insulated tools during installation and wiring.
- ◆ Equipment requiring grounding must be permanently connected to the protective earth (PE). When connecting cables, the protective earth wire must be connected first; when replacing equipment, the protective earth wire must be disconnected last.
- ◆ Before contacting equipment terminals, measure the voltage at the contact points to ensure there is no risk of electric shock

- ◆ During equipment operation, prevent any foreign objects from falling into the equipment interior

4.8 Power on

- 1) Check all the power cables and communication cables between Battery Control Box and inverter. Check and make sure grounding is connected.
- 2) Turn on the Breaker on the Battery Control Box.
- 3) Switch ON the disconnection device between Battery Control Box and inverter if available.
- 4) When battery and inverter have completed power & communication connections , and the inverter is operational:
Standalone System: short-press the ON/OFF button for 1 second to activate the system.
Parallel System:
activation sequence: Slave units first → Master unit last (using same operation procedures as single system).
- 5) When battery and inverter lack power/communication connections or inverter is inactive:Activation sequence:
Standalone System:
long-press ON/OFF button for 10+ seconds to start the system.
Parallel System:
Slave units first → Master unit last .
Slave activation (circuit breaker ON): Short-press button for 1 second .
Master activation (circuit breaker ON): Requires sustained 10-second press.

4.9 Power off

- 1) Standalone System:
Long-press ON/OFF button for 3 seconds,and then turn off the circuit breaker.
- 2) Parallel System:
Individual shutdown: Long-press any unit's button for 3 seconds,
Full system shutdown: Automatic complete shutdown 1 minute after any individual shutdown,and then turn off the circuit breaker.

5. Transport and Maintenance

5.1 Capacity calibration

It is better to fully charge-discharge the battery for the capacity calibration at least once every six months (if available). Please conduct the calibration maintenance according to the following steps:

- 1) Make sure there is a relatively stable power supply source to charge the battery at a maximum charge current of 50A, e.g. grid.
- 2) Make sure the battery discharges through PCS at a maximum discharge current of 50 A.
- 3) Set the inverter, and ensure that the DOD is 100% (if available), the maximum charge current is less than 50 A (20.4 A is better), while the maximum discharge current is 50 A.
- 4) Adjust the inverter working mode and discharge the battery till power off, and keep it for at least 30min;
- 5) Adjust the inverter working mode and charge the battery to 100%, and keep it for at least 30min;
- 6) Adjust the inverter working mode and discharge the battery till power off, and the capacity calibration is finished;
- 7) Charge the battery to 30%~80%SOC, and then set the inverter as before the capacity calibration.

5.2 Annual inspection

Every year after installation. The connection of power connectors, grounding points, power cables and screws are to be checked. Make sure there is no loosening, fracture or corrosion at any connection point. Check the installation environment such as dust, water, insect etc. and make sure it is suitable for IP66 battery system.

5.3 Transport requirement

The product transportation process shall meet the following requirements:

- Observe the caution signs on the packaging of the device before transportation.
- Battery energy state is 20%~50%, disconnect the high voltage circuit.
- When carrying the equipment by hand, wear protective gloves to prevent injuries.
- Handle the product gently during transportation to prevent dropping, tumbling

and heavy pressure.

- Prevent severe vibration, inversion, impact, extrusion, sun and rain during product transportation.

5.4 Storage

- ◆ The storage location should comply with local laws and regulations.
- ◆ The device must be stored indoors.
- ◆ Do not store battery packs together with other items. Firefighting equipment such as fire extinguishers that meet requirements must be placed in battery pack storage areas.
- ◆ Do not remove the original packaging material and check the outer packaging material regularly.
- ◆ If the battery is stored for long time, it is required to charge it every six months, and the recommended SOC should be 50%~55%. The battery shall not be stored for more than 12 months if the storage temperature is -10 ~ 25°C, not more than 6 months if the storage temperature is 25 ~ 35°C and not more than 3 months if the storage temperature is 35 ~ 50°C.
- ◆ Stack the device in accordance with the caution signs on the carton to prevent the device falling down and damage.
- ◆ Do not place it upside down.

5.4 Equipment Maintenance and Replacement

- ❖ Before maintaining or replacing equipment, the device must be powered off. Wait for the duration indicated on the delay label attached to the equipment before proceeding with the operation. The device may only be powered on for continued use after the fault has been completely resolved or the replacement operation has been completed.
- ❖ Battery energy storage systems pose a high risk of fire, and faulty battery packs may release flammable or toxic gases. Battery pack replacement may only be performed or supervised by professionals who are familiar with and have mastered the necessary preventive measures.
- ❖ When replacing battery packs, use only battery packs manufactured by our company. Mixing with battery packs of other brands is strictly prohibited.
- ❖ When a battery pack is faulty, its surface temperature may be high. Direct contact with bare hands is prohibited.

- ❖ Do not store faulty battery packs in flammable or explosive environments, and keep non-professionals away from them.
- ❖ During the storage of faulty battery packs, regular monitoring is required to ensure there is no leakage of electrolyte, overheating, flames, or other abnormal phenomena.

5.5 Disposal instructions

Private disassembly is prohibited; it must be performed by a professional and followed by proper recycling procedures.